

The Chem-Tech Series XP with peristaltic technology delivers worry-free dosing in a modern design. Each and every component of the Series XP is designed and manufactured for optimum reliability and durability for **REAL Performance**.

The electronic timing circuit in the adjustable 'A' Models provides **reliable** pump control, without relying on mechanical adjustment components that wear out over time.

The intuitive interface and controls provide **easy** operation and the peristaltic design is virtually maintenance-free.

Tailor-made for the water conditioning market, the Series XP offer **affordable** solutions in both initial cost and operation.

A rugged gear train and computer-aided peristaltic design ensure **long-lasting** performance.

Features

- Fixed Models. Simple and straight forward fixed rate pumps for applications where economy and ease-of-use are required.
- Adjustable Models. Electronic timer module provides a 20:1 turndown control for enhanced flexibility.
- Pulse Input Models. Internal timer accepts pulses from a contacting head water meter. Adjustable to run the pumps from .1 to 1 sec., .2 to 10 sec., or from 1.0 to 60 sec. per pulse.
- Flow Switch Activated Models. Activated when flow rate through the included 3/4" NPT flow switch reaches 1 GPM and deactivated when flow rate is less than 1 GPM.
- Dry Contact Input Models. Activates pump upon closure of a dry contact switch, and deactivates when opened. Pump equipped with a 6' lead for connection to the customer supplied switch.
- Timer Models. 7 Day – 8 Event Electronic Timer.
- Duplex Head Models. Two pump heads to deliver twice the flow, or the rated flow of two different chemicals simultaneously.
- Tubing Materials. Standard Norprene tube material in Low Pressure ratings - extended tube life, High Pressure ratings - meet demanding system requirements. Fluran tubing - greater chemical resistance: contact Technical Service for compatibility.

Controls



Fixed Rate Model

- Simple and straight-forward fixed rate pumps.

Adjustable Model

- 20:1 Turndown Control

Three Input Models

- Pulse Input
- Flow Switch Activated
- Dry Contact Input

Timer Model

- 7 Day – 8 Event Electronic Timer

Operating Benefits

- Reliable metering performance.
- Mixed fluid capable. Inherently degassing.
- Extended tube life.
- Rugged, sealed gear train.
- Easy tube change-out.
- Self priming.
- Chemical resistant materials.
- Simple installation.



Aftermarket

- KOPkits
- Gauges
- Dampeners
- Pressure Relief Valves
- Tanks
- Pre-Engineered Systems
- Process Controllers (PULSAblue, MicroVision)



Tested and Certified by WQA
against NSF/ANSI 61-Section 8.
and CSA B483.1



CHEM-TECH Series XP
Peristaltic Metering Pumps

Specifications and Model Selection

MODELS:	Flow	Pressure Rating - PSI (Bar)				Tube Size	Speed (RPM)
		Single Head Options			Duplex		
		'H' Tube	'L' Tube	'F' Tube	'L' Tube		
XP004	4 GPD (0.6 LPH)	125 (8.6)	80 (5.5)	60 (4.1)	80 (5.5)	2	30
XP007	7 GPD (1.1 LPH)				50		
XP009	9 GPD (1.4 LPH)	110 (7.6)	70 (4.8)	50 (3.4)	70 (4.8)	3	30
XP015	15 GPD (2.4 LPH)				50		
XP014	14 GPD (2.3 LPH)	100 (5.9)	50 (3.4)	40 (2.8)	50 (3.4)	4	30
XP023	23 GPD (3.6 LPH)				50		
XP030	30 GPD (4.7 LPH)	80 (5.5)	40 (2.8)		40 (2.8)	6	30
XP050	50 GPD (7.9 LPH)				50		
XP048	48 GPD (7.5 LPH)		25 (1.7)		25 (1.7)	8	30
XP080	80 GPD (12.6 LPH)				50		

Engineering Data

Drive:

Fixed Rate

On. Off Only
Duplex Head
Dry Contact Input
Flow Switch Activated
7 Day-8Event Electronic Timer

Adjustable

20:1 Turndown
Duplex Head
Dry Contact Input
Flow Switch Activated

Pulse Input

.1 to 1 Second Timer
.2 to 10 Second Timer
1 to 60 Second Timer

Tubing:

Norprene Low Pressure
Norprene High Pressure
Fluron

1/4" or 3/8" Tube Fittings
1/4" or 3/8" Tube Fittings
1/4" or 3/8" Tube Fittings (Does not include strainer & Injector accessories)

Viscosity Max CPS:

300 CPS

Enclosure:

NEMA 3R / IP31
(In Horizontal Position)

Power Input:

115 VAC/60 HZ, 1/6 HP
230 VAC/50/60 HZ
230 VAC/60 HZ

Temperature Limitations:

104°F / 40°C max.

Shipping Weight:

8 lbs. / 3.63kg.

Custom Engineered Designs – Pre-Engineered Systems

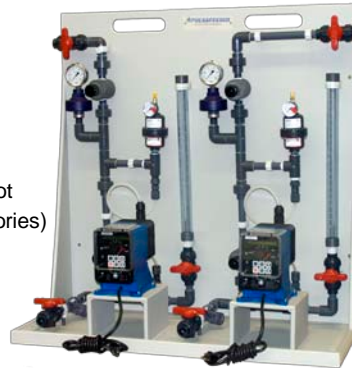

Pre-Engineered Systems

Pulsafeeder's Pre-Engineered Systems are designed to provide complete chemical feed solutions for all electronic metering applications. From stand alone simplex pH control applications to full-featured, redundant sodium hypochlorite disinfection metering, these rugged fabricated assemblies offer turn-key simplicity and industrial-grade durability. The UV-stabilized, high-grade HDPE frame offers maximum chemical compatibility and structural rigidity. Each system is factory assembled and hydrostatically tested prior to shipment.

Dimensions All dimensions expressed as inches (mm)

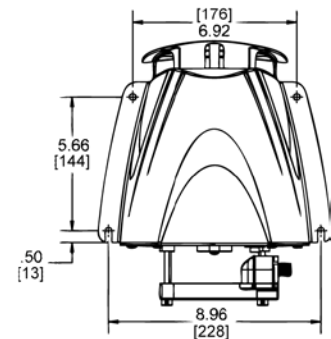
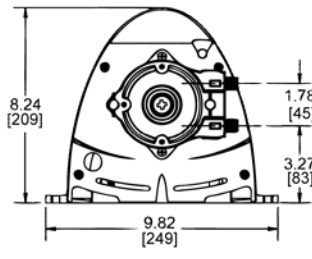
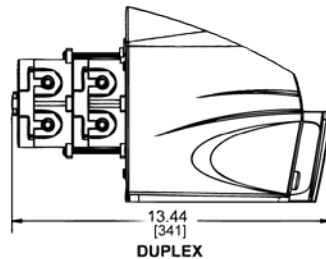
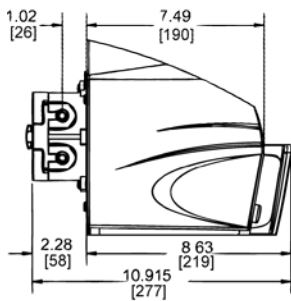

pulsafeeder.com



27101 Airport Rd
Punta Gorda, FL 33982
Phone: ++1(941) 575-3800
Fax: ++1(941) 575-4085

An ISO 9001 and ISO 14001 Certified Company



CTI009 I10