

# **AquaMatic Series**

**A100 and A200**

**Stager Controls**





## Table of Contents

Introduction To AquaMatic Series A100 and A200 Stager Controls	3
Specifications	4
Applications	5
Features	6
Cycle Time Programming	7
Setting A100 Regeneration Frequency	9
Series A100 Standard Wiring Diagram	10
Series A200 Standard Wiring Diagram	11
Regeneration Initiation Options	12
Troubleshooting	13

## Introduction To AquaMatic Series A100 and A200 Stager Controls

This series of AquaMatic controls combines an electromechanical timer with a stager. A stager is a rotary pilot valve with multiple ports through which control fluid (air or water) is directed to either pressurize or vent AquaMatic diaphragm valves. Control of a wide range of water treatment systems such as water softeners and filters is possible. Customer applications are also available.

There are two base models which vary with regard to the timer furnished.

- The A100 series initiates a regeneration based on a time set on the built-in time clock.
- The A200 series initiates a regeneration when a signal is received from a water meter, sensor, pressure differential switch, push button or other remote device.

Either series of controls is equipped with a cycle timer which may have from one to 10 cycles if desired. The maximum cumulative time available for timed cycles is 102 minutes. The cycle times can be programmed in three minute increments with a minimum cycle length of three minutes.

A variety of stager models may be used with the A100 and A200 series controls. There are five stager designs available:

- Series 48 brass stager with six ports
- Series 51 and 96 brass staggers with eight ports
- Series 58 PVC stager and 59 brass stager with sixteen ports

The 48 stager can control typical softener or filter systems as well as sequential backwash filters. For more complex systems such as non-standard softeners, twin alternating softeners or filters, the 51 or 58 staggers are required. The 96 stager design is similar to that of the 51, but is rated for 250 psi (17 bar) and used for high pressure systems. The 59 brass stager design is identical to the 58 PVC stager.

# Specifications

- Power Requirements: ..... 120 VAC/60 Hz/3 Watts  
220 VAC/50 Hz/3 Watts  
220 VAC/60 Hz/3 Watts  
24 VAC/50 Hz/3 Watts
  
- Initiation Signal (A200 only): .....Line voltage (minimum of 3 minute signal duration)
  
- Stager Port Sizes: .....All inlet, control, and drain ports have 1/8 inch NPT threads  
(except Series 58 and 59 inlet and drain ports are 1/4 inch NPT)
  
- Control Fluid: ..... Clean Air or Water
  
- Control Pressure: ..... 125 psi (8.5 bar) maximum for Series 48, 51, 58, and 59  
250 psi (17 bar) maximum for Series 96 stager
  
- Control Temperature: ..... 140°F (60°C) (Atmospheric)
  
- Enclosure Options: ..... NEMA 1  
NEMA 4  
NEMA 4XFG

# Applications

<b>Single Unit Controls</b>	<b>Model Number</b>
Typical Softeners and Filters	
Time Initiated	A148
Signal Initiated	A248
More Complex Softeners and Filters	
Time Initiated	A151
Signal Initiated	A251
High Pressure (250 psi/17 bar) Stagers for Typical and Complex Softeners and Filters	
Time Initiated	A196
Signal Initiated	A296

<b>Multiple Unit Controls</b>	<b>Model Number</b>
Twin Alternating Softeners and Filters	
Time Initiated	A158TA
Signal Initiated	A258TA
Sequential Filters (Backwash Only)	
Time Initiated	A148
Signal Initiated	A248
2 Unit Sequential Filters (Backwash and Rinse)	
Time Initiated	A151
Signal Initiated	A251
3 or 4 Unit Sequential Filters (Backwash and Rinse)	
Time Initiated	A158
Signal Initiated	A258

## Features

### **Standard Features:**

- NEMA 1 Enclosure
- 120 VAC/60 Hz/3 Watts
- Homing Feature — If the stager gets out of sequence with the timer, the homing feature returns the stager to the service position when the timer returns to the service position.
- 7 Day Time Clock (Series A100 only)

### **Optional Features:**

- NEMA 4 or NEMA 4XFG Enclosure
- 220 VAC/50 Hz/3 Watts
- 220 VAC/60 Hz/3 Watts
- 24 VAC/50 Hz/3 Watts
- 6 Day Time Clock (Series A100 only)
- External push-button for Regeneration (Series A200 only)
- Status Lights
- Rotary switch for electrical output (0.25 amps) in each position (not available with Series 51 stagers)
- Extra cam and switch option to provide either a dry or powered contact closure during any or all cycles

## Cycle Time Programming

### Series A100 and A200

1. Remove the thumbscrew from the mounting bracket of the timer and swing the timer to the left.
2. Pull up on the first pin (Start Cycle #1) of the pinwheel to mark the start of the regeneration sequence (see Figure 1).
3. Use the PIN TIME CHART below, to determine the number of pins to be left in the DOWN position. The number of pins left in the DOWN position represent the duration of the cycle (each pin equals approximately 3 minutes).
4. Pull up the pin that represents start of the next cycle (Start Cycle #2) and repeat step 3 to determine the duration of this cycle.
5. Repeat steps 3 and 4 as needed for the remainder of steps in the regeneration process. The last pin that is left in the UP position will send the controller back into the Service position.
6. Return the timer to the proper mounting position and secure it using the thumbscrew provided. Ensure that all electrical wires are located away from the bottom of the timer.

**NOTE:** The number of pins in the UP position on the pinwheel must equal exactly the number of positions of the stager. Total regeneration time cannot exceed 102 minutes.

PIN TIME CHART							
Number of Pins DOWN	Time (Min.)		Number of Pins DOWN	Time (Min.)		Number of Pins DOWN	Time (Min.)
0	3		12	39		24	75
1	6		13	42		25	78
2	9		14	45		26	81
3	12		15	48		27	84
4	15		16	51		28	87
5	18		17	54		29	90
6	21		18	57		30	93
7	24		19	60		31	96
8	27		20	63		32	99
9	30		21	66		33	102
10	33		22	69			
11	36		23	72			

## Cycle Time Programming (Continued)

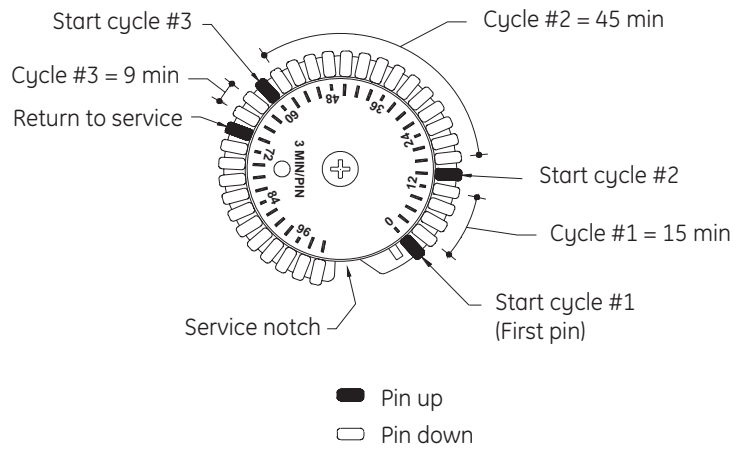

Figure 1 Typical Pinwheel Setting

## Setting A100 Regeneration Frequency

### Setting Days:

1. Pull all skipper pins outward away from dial face (see Figure 2).
2. Rotate skipper wheel until Day Arrow is aligned with either the current day (for the 7 day wheel) or the number 1 (for the 6 day wheel).
3. Depress skipper pin(s) at day(s) regeneration is desired.

### Setting Time of Day:

1. Grasp timer knob and pull outward.
2. Rotate in either direction until actual time of day is aligned with Time Arrow.
3. Release timer knob.

**NOTE:** With the time of day properly set, the controller will regenerate at approximately 2:30 AM. If you prefer to have the unit regenerate at an earlier or later time, set the current time of day accordingly. A label has been provided so that you can apply it to indicate the correct time of day.

**EXAMPLE:** To set the unit to regenerate at 4:30 AM (2 hours later), set the clock 2 hours earlier than the actual current time. Position the label provided on the 24-hour dial while aligning the mark of the current time with the Time Arrow. Press the label in place.

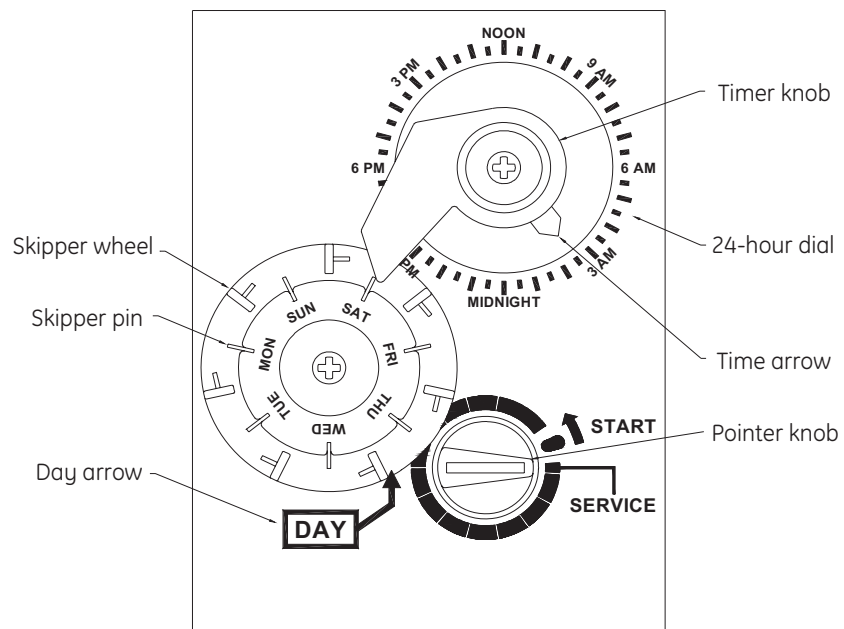

Figure 2 A100 Timer Faceplate



# Series A200 Standard Wiring Diagram

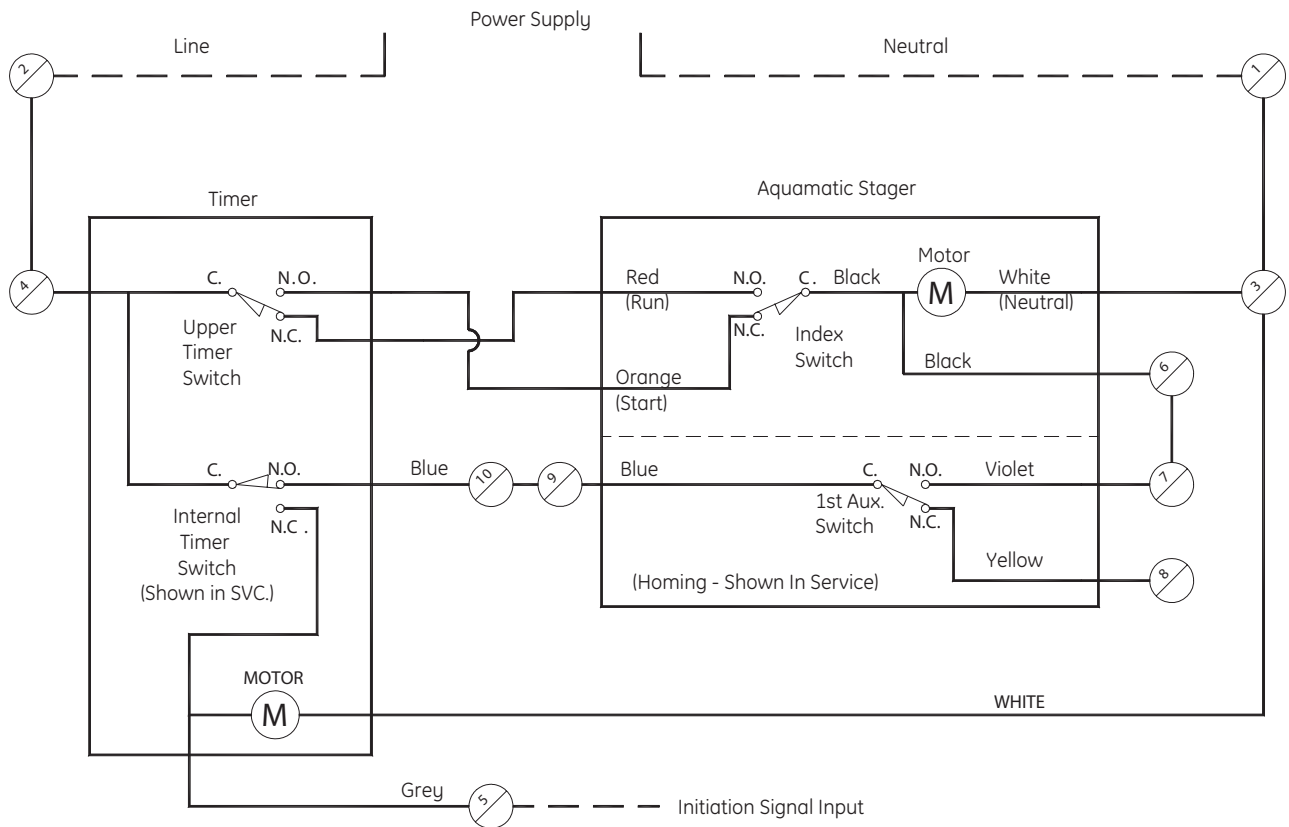

Figure 4

## Regeneration Initiations Options

### Series A100:

Manual (internal):

Open enclosure. Depress RED BUTTON and turn counterclockwise to the START position (see Figure 2).

Automatic:

Preset day and time.

### Series A200:

Manual Regeneration (internal): Open enclosure. Depress RED BUTTON and release.

External Electrical Signal:  
(3 minute duration)

Differential Pressure Switch, water meter, or other remote device (See Figure 5).

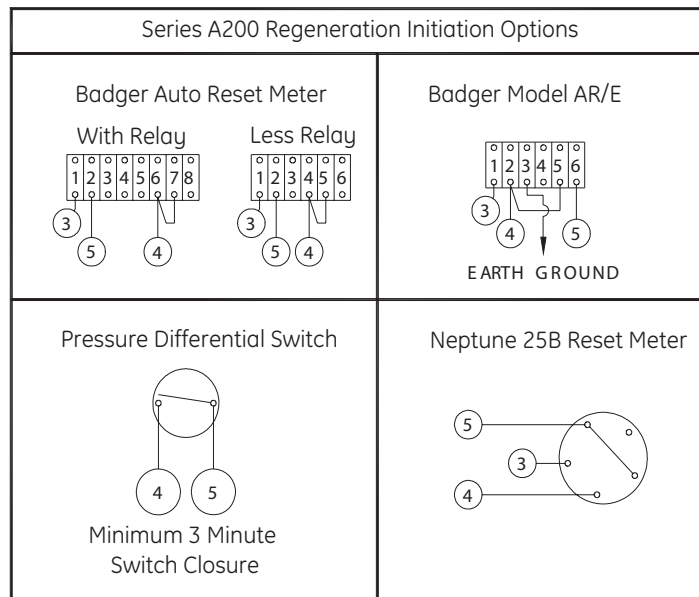

Figure 5

## Troubleshooting

Problem	Solution
Timer and Stager are out of sequence.	<ul style="list-style-type: none"> <li>• Check that the number of pins that are in the “UP” position on the timer pinwheel (Figure 2), match EXACTLY the number of notches in the stager cam assembly</li> <li>• Make sure that there are no wires coming in contact with the pinwheel assembly.</li> <li>• Manually rotate the stager assembly to the “Service” position. Then, check the operation of the timer pinwheel assembly by depressing and then releasing the micro-switch located on the pinwheel. You can repeat this for each step of the regeneration cycle to ensure that the stager and timer are working properly.</li> <li>• Verify the connections of the “Homing” feature. (If Applicable, See Figures 3 and 4)</li> </ul>
Stager does not advance automatically,	<ul style="list-style-type: none"> <li>• Manually rotate the stager assembly approximately 1/4 inch. The stager motor should take over the operation and advance the stager to the next step. The “Homing” feature will return the stager to the “Service” position automatically.</li> <li>• Verify that all wiring connections are made correctly. (See Figures 3 and 4)</li> <li>• Check that the correct voltage and frequency are being used as specified for the control.</li> </ul>
Initiation signal will not start the control. (A200 Stager Control Only)	<ul style="list-style-type: none"> <li>• Verify that the initiation signal is connected properly to terminal #5 on TB1. (See Figure 4)</li> <li>• Check that the correct voltage and frequency are being used as specified for the initiation input signal.</li> <li>• Ensure that the initiation signal has a minimum duration of 3 minutes.</li> <li>• Check all wiring according to the wiring diagram provided with the control.</li> </ul>



